



DEFENDER™ 5000

Washdown Bench Scales (Single Range)



Multifunctional Bench Scale for Standard Industrial Applications

The OHAUS next generation Defender 5000 Series multifunctional bench scale is ideal for a multitude of applications, including production, packaging, inventory and shipping. Built durably and equipped with advanced features such as maximum configurability print output, GMP/GLP data output, library/user management, and multiple connectivity options - the Defender 5000 Series is designed to handle demanding industrial and commercial applications.

Unique Features:

- **Indicator Guides The User with On-Screen Prompts**
See results clearly on the large backlit display. The alphanumeric keypad and function keys allow for a simplified user experience. On-screen prompts and soft keys will guide you through the operation.
- **Durably Constructed To Withstand Harsh Industrial Environments**
Durably constructed with a stainless steel platform, frame, IP67 loadcell and IP68 indicator, the Defender meets OIML/EC Type approvals.
- **Multiple Application Modes and High Storage Capacity for Greater Flexibility**
Features common industrial modes and supports a 50,000 item library and 1,000 user profiles which can be downloaded/uploaded for easy set-up (with SD Card.) Also equipped with GMP/GLP capability with time/date for result traceability.
- **Multiple Connectivity Options for Convenient Data Transfer and Storage**
Results can be stored in the Micro SD card. Data output via built-in RS232 or optional interfaces including RS232/RS485/USB device, Ethernet and Bluetooth/WiFi, Analog Output and Discrete I/O with relays.

DEFENDER™ 5000 Washdown Bench Scales

Simplified Use

Results can be read easily on the Defender™ 5000's large transfective dot matrix display, even in bright sunlight. The SmartText 3.0 interface will guide you through all of the Defender™ 5000's unique and advanced features. With five soft keys, SmartText 3.0 makes an advanced scale very simple to use, and reduces training time for operators.

Durable Construction

With OIML/EC-type approvals, the Defender™ 5000 can be used for both general and legal-for-trade applications. For standard industrial applications, the Defender™ 5000 bench scales offer durable performance at a practical price.

Simple Operation

Featuring most common applications including Percent Weighing, Parts Counting with APW optimization, Checkweighing or Checkcounting, Filling and Dynamic Weighing or Display Hold, the Defender™ 5000 meets the weighing and measurement needs of practically every industrial application or manufacturing process. Many application modes eliminate the need for long and complicated manual calculations. GMP/GLP with time/date allows for traceability of results.

Equipped with Micro SD card, the Defender™ 5000 can support storage of up to 50,000 items and 1,000 user profiles. Weighing results can also be stored in Alibi or regular format, addressing all your data storage needs.

Multiple Connectivity Options

Weighing results can be easily exported through the standard RS232 port. Additional connectivity options include a second RS232, RS485 or USB device; USB Host, Ethernet, and WiFi/Bluetooth.

Using the Analog option (either 4-20mA or 0-10V) or two In/four Out discrete I/O, the new Defender™ 5000 indicator can also be used for systems including PLC.



Front Mount Bench Scale Specifications

Model	D52XW15WQR5	D52XW15WQL5	D52XW30WQL5	D52XW60WQL5	D52XW60WQX5	D52XW150WQX5
Capacity × Readability	15 kg × 1 g		30 kg × 2 g	60 kg × 5 g		150 kg × 10 g
Min APW (g)	0.05		0.1	0.25		0.5
Internal Counting Resolution	1:300000			1:240000		1:300000
Certified Model	D52XW15WQR5-M	D52XW15WQL5-M	D52XW30WQL5-M	D52XW60WQL5-M	D52XW60WQX5-M	D52XW150WQX5-M
Certified Capacity × Readability	15 kg × 5 g		30 kg × 10 g	60 kg × 20 g		150 kg × 50 g
Min APW (g)	0.25		0.5	1		2.5
Internal Counting Resolution	1:60000					
Linearity/Repeatability	±2d					
Indicator	TD52XW					
Mount	Stainless steel front-mount bracket with handle					
Base Construction	Stainless steel removable weighing platform with stainless steel frame, silicon sealed IP67 stainless steel loadcell					
Safe Overload Capacity	150% of maximum capacity					
Stabilization Time	Within 1 second					
Operating Temperature Range	-10°C to 40°C					
Scale Dimensions (A × B × C × D × E × F)	305 × 305 × 95 × 60 × 118 × 588 mm	400 × 400 × 110 × 70 × 118 × 677 mm			500 × 500 × 120 × 80 × 118 × 772 mm	
Shipping Dimensions (L × W × H)	480 × 445 × 363 mm	800 × 600 × 235 mm			994 × 680 × 235 mm	
Approx. Net Weight	9 kg	17 kg			21 kg	
Approx. Shipping Weight	11 kg	19 kg			24 kg	

DEFENDER™ 5000 Washdown Bench Scales

Column Mount Bench Scale Specifications

Model	D52XW15WQR6	D52XW15WQL7	D52XW30WQL7	D52XW60WQL7
Capacity × Readability	15 kg × 1 g		30 kg × 2 g	60 kg × 5 g
Min APW (g)	0.05		0.1	0.25
Internal Counting Resolution	1:300000			1:240000
Certified Model	D52XW15WQR6-M	D52XW15WQL7-M	D52XW30WQL7-M	D52XW60WQL7-M
Certified Capacity × Readability	15 kg × 5 g		30 kg × 10 g	60 kg × 20 g
Min APW (g)	0.25		0.5	1
Internal Counting Resolution	1:60000			
Linearity/Repeatability	±2d			
Indicator	TD52XW			
Column	374 mm stainless steel	704 mm stainless steel		
Base Construction	Stainless steel removable weighing platform with stainless steel frame, silicon sealed IP67 stainless steel loadcell			
Safe Overload Capacity	150% of maximum capacity			
Stabilization Time	Within 1 second			
Operating Temperature Range	-10°C to 40°C			
Scale Dimensions (A × B × C × D × E × F)	305 × 305 × 95 × 60 × 604 × 442 mm		400 × 400 × 110 × 70 × 934 × 570 mm	
Shipping Dimensions (L × W × H)	480 × 445 × 363 mm		800 × 600 × 235 mm	
Approx. Net Weight	10 kg		20 kg	
Approx. Shipping Weight	11 kg		21 kg	

Model	D52XW60WQX7	D52XW150WQX7	D52XW60WQV8	D52XW150WQV8
Capacity × Readability	60 kg × 5 g	150 kg × 10 g	60 kg × 5 g	150 kg × 10 g
Min APW (g)	0.25	0.5	0.25	0.5
Internal Counting Resolution	1:240000	1:300000	1:240000	1:300000
Certified Model	D52XW60WQX7-M	D52XW150WQX7-M	D52XW60WQV8-M	D52XW150WQV8-M
Certified Capacity × Readability	60 kg × 20 g	150 kg × 50 g	60 kg × 20 g	150 kg × 50 g
Min APW (g)	1	2.5	1	2.5
Internal Counting Resolution	1:60000			
Linearity/Repeatability	±2d			
Indicator	TD52XW			
Column	704 mm stainless steel		1004 mm stainless steel	
Base Construction	Stainless steel removable weighing platform with stainless steel frame, silicon sealed IP67 stainless steel loadcell			
Safe Overload Capacity	150% of maximum capacity			
Stabilization Time	Within 1 second			
Operating Temperature Range	-10°C to 40°C			
Scale Dimensions (A × B × C × D × E × F)	500 × 500 × 120 × 80 × 934 × 665 mm		610 × 610 × 130 × 90 × 1234 × 773 mm	
Shipping Dimensions (L × W × H)	994 × 680 × 235 mm		1165 × 780 × 235 mm	
Approx. Net Weight	23 kg		37 kg	
Approx. Shipping Weight	27 kg		42 kg	

Model	TD52XW
Construction	304 stainless steel with sand blasted surface treatment
Protection	IP68
Weighing Units	kg, g, lb, oz, lb:oz, metric tonnes, short ton, custom unit
Application Modes	Weighing, Percent weighing, Piece Counting with Optimized APW, Checkweighing/Checkcounting, Filling, Dynamic Weighing/Display Hold
Display	Dot matrix LCD with white LED backlight, 256 x 80 pixels
Keyboard	6 function, 5 quick, 12 alpha numeric membrane switches
Auto-zero Tracking	Off, 0.5 d, 1 d or 3 d
Zeroing Range	2% or 100% of capacity
Interface	Standard RS232, Optional Ethernet, WiFi/Bluetooth, RS232/RS485/USB, USB Host, Analog output, 2 In/4 Out digital I/O
Power	100-240 VAC / 50/60 Hz Universal Power Supply, Rechargeable Lithium battery (Optional)
Battery Life	20 hours continuous use
Calibration	Zero, Span or 3 point-Linear

Application Modes



Weighing:

Determine the weight of items in the selected unit of measure.



Percent Weighing:

Measure the weight of a sample displayed as a percentage of a pre-established reference weight.



Parts Counting: Count samples of uniform weight. Advanced auto-optimization software recalculates the average piece of weight as the overall weight increases.



Filling:

Fill a container to a target weight. Progress bar displays filling status. Connect with Discrete I/O option kit for auto-filling system.



Checkweighing/Counting: Compare the weight/count of a sample against target limits. Connect with Discrete I/O and Light Tower Kit for external check lights.



Dynamic Weighing and Display Hold: Weigh an unstable load. Scale takes an average of weights over a period of time. The Display Hold feature manually and automatically holds the last stable weight on the display.

Other Standard Features and Equipment

User-configurable resolution up to dual range 15,000d/3,000e, 150% overload capacity protection, checkweighing symbols with selectable operation and audible signal settings, menu lock switch, multiple selectable operating languages, selectable environmental and auto-print settings, stability indicator, overload/underload indicators, selectable adjust contrast settings, auto-dim display, auto-off, auto tare, 100-240 VAC 50/60 Hz internal universal power supply - Lithium Ion rechargeable battery with 20 hour standard continuous use (optional), 304-grade stainless steel platform and frame, stainless steel IP68 indicator, IP67 load cell, non-slip adjustable rubber feet, a Wheel Kit option is also available for scales up to 300 kg.

Additional Features

A total of six print templates are available to ensure you can print out all of the data you need. A simple template is predefined for quick printing, as well as five templates you can customize so you can print the exact information necessary for your application - eliminating confusion and time to sift through excess unnecessary data.

Compliance

- **Metrology:** OIML R76 (Indicators: Certificate R76-2006-A-NL1-18.13, Load Cells: Certificates R60/2000-NL1-12-41, R60/2000-NL1-12-42, R60/2000-NL1-12-43, R60/2000-NL1-14.24)
- **Product Safety:** IEC/EN 61010-1; CAN/CSA C22.2 61010-1; UL61010-1
- **Electromagnetic Compatibility:** IEC/EN 61326-1 Class B, basic environments; FCC Part 15 Class B; Canada ICES-003 Class B
- **Compliance Marks:** CE; CSA; RCM

Accessories

Battery Kit, Li-ion, TD52	30424405	M16 Gland with Ferrite, to TD52	30379716
USB Host for Dongle, TD52	30424406	Micro SD Card, 8G	30303533
Light Tower, R-Y-G, IP65, 24VDC	30424021	Analog Output Kit, TD52 ³	30424403
In-use Cover Kit, TD52P	30424022	Second RS232/RS485/USB Kit, TD52 ²	30424404
In-use Cover Kit, TD52XW	30424023	I/O with Relay (2 In/4 Out) ³	30097591
In-use Cover set (10), TD52P	30469948	WiFi/BT Dongle, OHAUS ² (Requires 30424406)	30412537
In-use Cover set (10), TD52XW	30469949	Ethernet Kit, D52 ²	30429666
Printer Holder Kit, D52	30424025	Wheel Kit ¹ (up to 300 kg models)	30372146
Wall Mount Kit, SST, TD52XW	30424026	Wheel Kit, SST ¹	30616409
Wall Mount Kit, CS, TD52P	30424027	Printer SF40A	30045641
LC Extension Cable, 9 meters, D52 ¹	30424409	USB ²	30572923

¹ Cannot be used for legal-for-trade applications

² Only one of them can be used at the same time

³ Only one of them can be used at the same time

Outline Dimensions

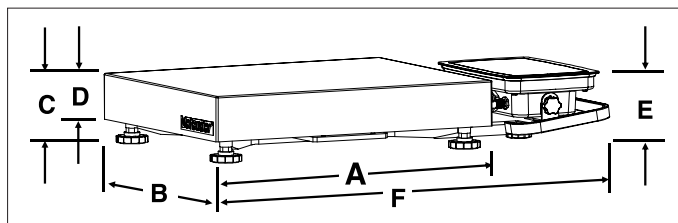
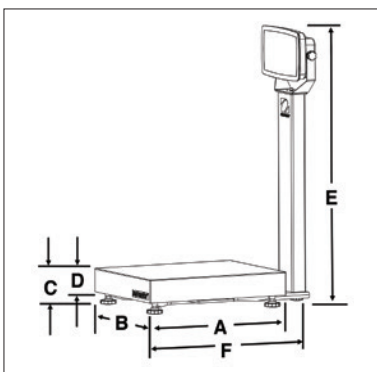

80775529_B 20240628 © Copyright OHAUS Corporation

OHAUS Europe GmbH

e-mail: ssc@ohaus.com

Tel: 0041 22 567 53 19

e-mail: tsc@ohaus.com

Tel: 0041 22 567 53 20

www.ohaus.com

The management system governing the manufacture of this product is ISO 9001:2015 certified.

